

## APPENDIX L

2006 Edition, Published January 1, 2006; Document Revision Date: January 1, 2006

### THE OHIO STATE UNIVERSITY SAMPLE SPECIFICATION CONDENSER WATER TREATMENT SYSTEM

#### 1. GENERAL

##### .1 REFERENCE

Section 23 63 05, Condensers.

##### .2 SCOPE OF WORK INCLUDED

- .2.1 Furnish and install water treatment systems for the chemical treatment of all condenser water systems shown on the drawings or implied in the specifications.
- .2.2 Provide a chemical treatment system for all closed loop systems described or shown on the drawings.
- .2.3 Contractor shall include in his bid, the cost of chemicals, and service contract for one year from the date of system start up as described herein.

#### 2. PRODUCTS

##### .1 CONDENSER WATER TREATMENT

- .1.1 Provide one impulse water meter on a make up water line to each tower. Meter will be of bronze body type by Rockwell, Badger or Hershey. Plastic will not be accepted. It shall consist of a bronze body impulse water meter. All water meters shall be mounted no higher than 5' off the floor, with the register in full view. It shall register in cubic feet.
- .1.2 Each chemical system shall be a Morr Control wired duplex function controller in a metal, lockable cabinet with an on-off manual switch, test switch, power, and function indicating lights visible when the door is closed. Provide a duplex receptacle in the bottom of the panel. Each system will include an injection assembly and a magnatrol bleed valve model #18-A-23-V with in-line strainer. (Size indicated on drawing.) Chemical pump shall be LMI Model A111 capable of pumping .48 to 24 gpd at 75psi, 120/60/1. All parts in contact with a chemical solution shall be impervious to solutions used in cooling tower treatment. Pump shall incorporate an anti-siphon pressure relief valve.
- .1.3 Solids in the condenser water system shall be controlled by a JA-12-G-7-C-M3 (OSU) Morr controller. This unit will receive a signal from a quick disconnect probe, piped across the condenser pump. The dial model shall be a full linear scale, 0-3000 micro-Mho's of conductance. The controller shall provide a proportional linear output signal of 4 to 20 ma to the central building automation system. The controller shall contain a 15 amp relay to handle a chemical feed pump as well as the bleed solenoid. The unit is to be pre-wired with a duplex receptacle in the bottom of the cabinet.
- .1.4 See attached specification for Cooling Tower Water Treatment.
- .1.5 Furnish one test kit with all necessary apparatus and reagents to perform all required tests on the condenser water system necessary for proper control and monitoring. The test kit shall include a portable conductivity meter plus iron and copper test kits to monitor corrosion.

2. PRODUCTS (Cont'd)

.1 CONDENSER WATER TREATMENT (Cont'd)

- .1.6 Adequate sizing and operation of the control system and the chemical pumps shall be the responsibility of the chemical company.

.2 CLOSED LOOP SYSTEMS

- .2.1 The chemical treatment for the closed loop systems shall be nitrite based on the following:

- .2.1.1 The nitrite water treatment for the chilled water system shall be a liquid treatment, with an active ingredient range of 10 percent minimum to 35 percent maximum of nitrite, by weight.

It is the intent to maintain a nitrite level of 1000 PPM in the chilled water system. It shall incorporate selected alkalinity builders, dispersers, and buffers. The material shall give effective protection against corrosion of brass, steel, copper, cast iron, and solder.

The treatment must stay in suspension for one year in the shipping container without agitation. The product will be shot-fed in the chilled water system.

- .2.1.2 The treatment shall have no corroding or disintegrating effect on gaskets and pump seals.

- .2.1.3 The product shall meet F.D.A. and E.P.A. acceptance.

- .2.1.4 The material shall have the following characteristics:

Appearance	Color
Optional	Form
Free Flowing	Liquid
Density	9.3 pounds/gallon
Flash Point	None

- .2.1.5 Control levels shall be maintained at 1000 to 1200 ppm of nitrite. Chromates and phosphates will not be accepted.

- .2.2 Feed equipment shall consist of a shot-feeder piped across the circulation pumps with quarter turn ball valves on each side of the shot-feeder. Arrange piping so the feeder will be functional when any one of the condenser pumps is in operation. The feeder shall consist of two gallon cast steel body, funnel and valve, with drain and vent cocks. Piping and installation by this contractor.

- .2.3 Provide nitrite and pH test kits in the system test kit.

- .2.4 Treatment and equipment similar and equal in all aspects may be furnished by Vulcan, Calgon, Betz, Chardon, or Columbus Technical Services at the contractor's option.

3. INSTALLATION

- .1 Furnish and install all mounts, piping, tubing and valves necessary to install the complete operable water treatment system as shown on the drawings and under the supervision of the chemical company.

3. INSTALLATION (Cont'd)

**TYPICAL INSTALLATION - PULSE TIMER**  
PROPORTIONAL CHEMICAL FEED DUAL TIMER IN A COOLING TOWER

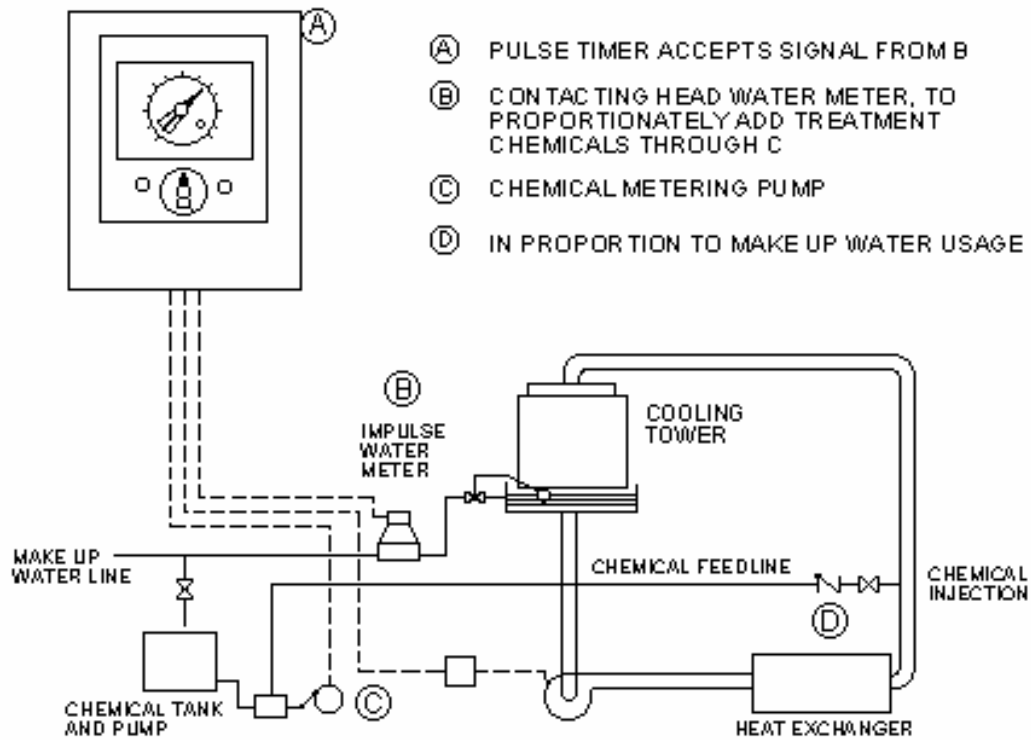

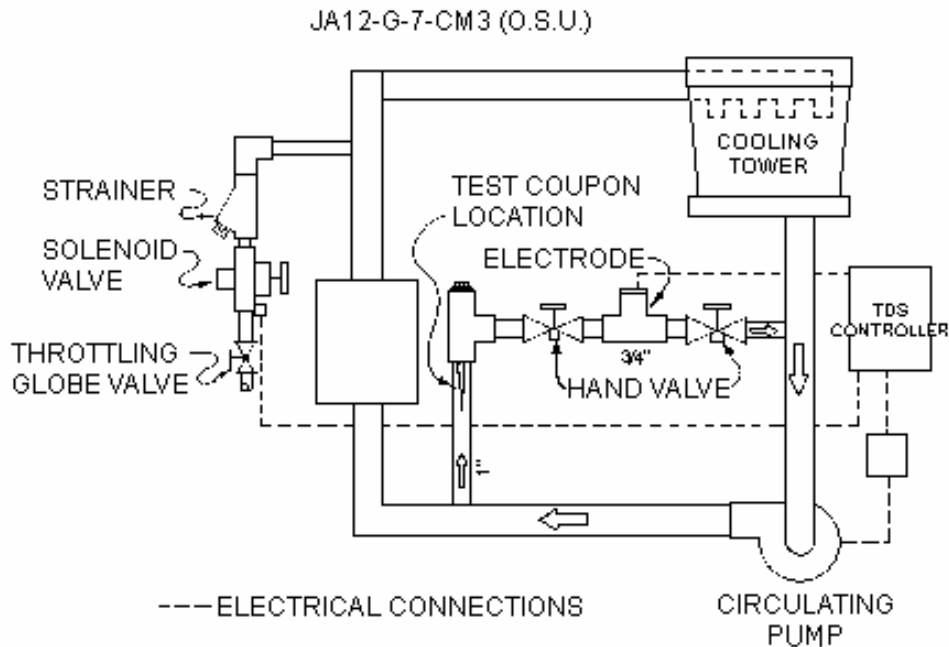

FIGURE 1 - TYPICAL INSTALLATION

Figure 1: Normal installation, with electrode installed in a bypass line across the tower recirculating pump. Hand valves are installed to facilitate removal of electrode for periodic cleaning or inspection.

- A. The power to the Ac/Trol unit is shown connected to the main cooling water circulating pump. Power should be supplied to the unit in this manner so the controller functions only when the system is in operation.
- B. The solenoid valve used should be 115 VAC with a minimum of 5 psi and a maximum of 125 psi pressure at this point. It should have a hand valve for flow throttling.
- C. The normal operation will be bleed-off only from the TDS controllers. Should there be a failure of the probe or internal operation of the TDS controller, the solenoid valve electric power can be unplugged and plugged into a dual timer.
- D. The normal operation of the dual timer is to take an impulse signal from the water meter and send a signal to the chemical pump to inject chemicals should the impulse meter or timers fail, the chemical pump can be unplugged and plugged into the TDS controller for feed and bleed.
- E. When installing the water meter, it is recommended that provisions be made for a backflow preventer or an air gap must be provided, in-line strainer, and manually operated bypass.

---

END OF APPENDIX L